

40[®]/45[®] CASSETTE BLOCKOUT SYSTEM WITH SYSTEM 40[®] SIDE CONTROL

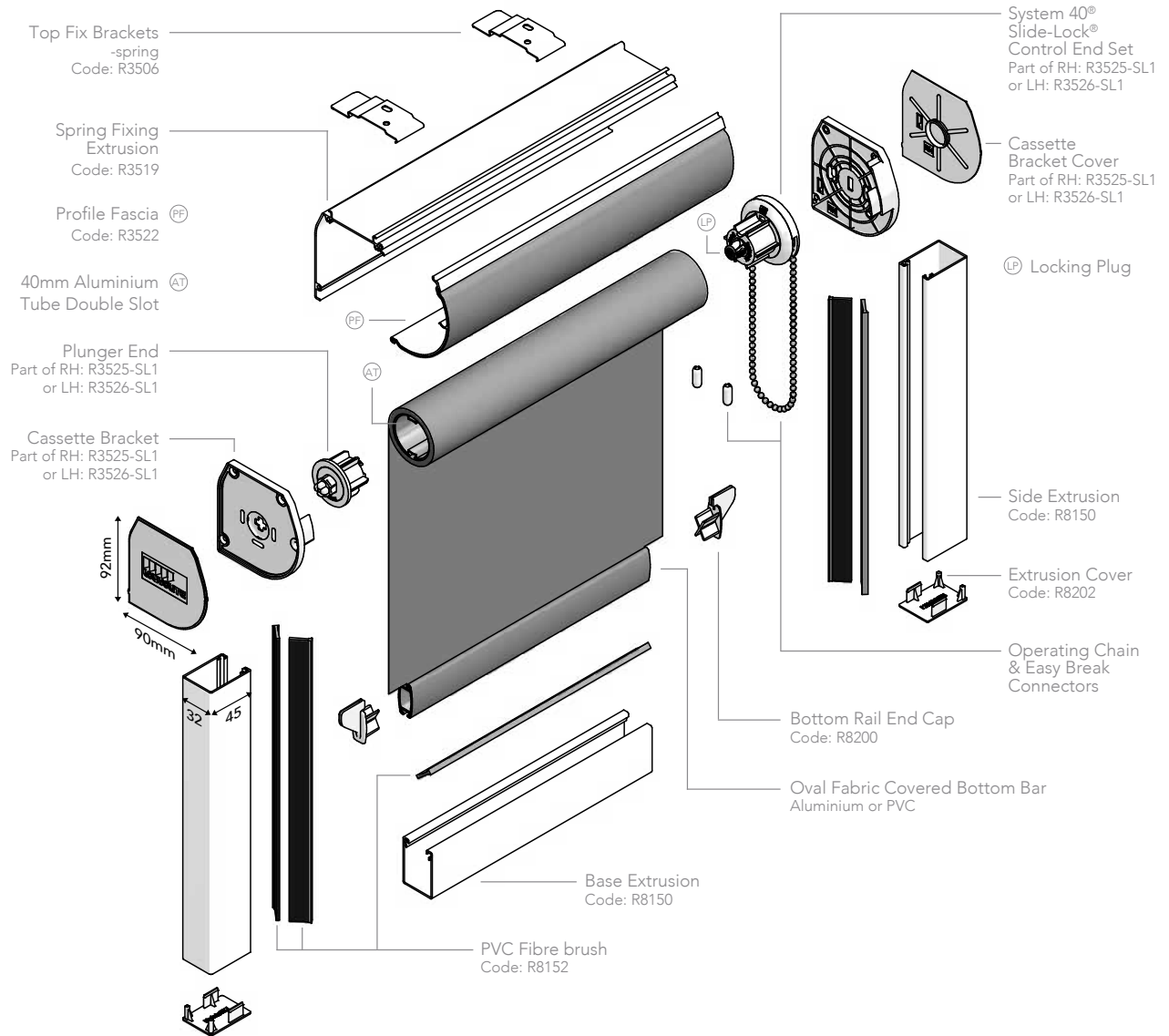

- Designed and manufactured in the UK, all Louvolite systems are 10 year life cycle tested to ensure long lasting performance.
- A robust, fully integrated system using a roller blind cassette and side channels with optional base channel.
- Can be used with System 32[®], 40[®], 40[®]+ and 45[®], using 32[®] Closed Cassette, 32[®]/40[®] Hybrid Cassette or 40[®]/45[®] Closed Cassette
- For blinds up to 3.5m wide.
- Slide-Lock[®] combines heavier holding weights with anti-fray features that ensure enhanced blind performance.
- Manufactured using high quality engineering grade polymer.
- Universal brackets and a spring idle end plunger enable easy and quick installation.
- Locking plug inside clutch ensures continued performance of larger blinds.
- Most effective when used with a blackout fabric.
- Can be motorised using Louvolite One Touch[®] Lithium Re-chargeable (R1710) or Hard Wired AC Motor (R1725).
- Available in white and black.

HARDWARE SPECIFICATION

Blockout Roller System

Our roller blinds are manufactured using the Louvolite System 32®, 40®, 40®+ or 45® roller blind mechanism with specifically designed grooved aluminium tubing. The specified fabrics are formed and held into the tube with locking tape. The side control units, manufactured in the UK, are made from glass filled Nylon 6, with an acetal sprocket and sprocket guard, and includes a locking spring.

The operating chain, No. 10 size in metal or plastic, ensures reliable performance, and improved chain location enables quick and easy on-site adjustment. The brackets are made from mild steel, zinc plated and powder coated, suitable for top, face or side fixing.

A sprung plunger end mechanism is positioned at the opposite end to the control unit, providing a more secure fit of the blind and smooth operation. The side control unit is fitted with a centre plug that ensures the mechanism operates smoothly even under extreme loads.

Depending on the size of blind required, these should be housed within a Louvolite System 32® Closed Cassette, a System 32®/40® Hybrid Cassette or a System 40®/45® Closed Cassette, which are white or black powder coated aluminium. The side and bottom channel are white or black powder coated aluminium. In the channel will be PVC fibre brushes.

Performance

To ensure a positive performance, all Louvolite roller system units are designed and manufactured in the UK using prime quality plastic materials and a dedicated steel locking spring. The sidewinders will lock into the bracket with the unique bracket securing pin for safety after installation.

10 year life cycle testing is done to ensure long lasting performance. The units will accept both metal or plastic operating chain providing reliable smooth operation.

Operation

Using manual or motorised operation, all blinds must

be compliant with the child safety elements of BS EN13120. Where children may be present, the chain must be fitted with easybreak connectors or cord tidy devices.

Bottom Bar

Made of either aluminium or plastic and wrapped in fabric. All fabric is formed and held into place with locking tape. Specifically designed end caps allow the bottom bar to slide along between the brushes housed within the side channels.

Maintenance

All of the roller blind system components

are manufactured using aluminium, treated steel and plastic. They do not present any corrosion problems in normal environments. The system has been designed for a smooth operation, together with a rigidity to prolong the window blind's working life.

Cassette

Roller blinds with a specially designed powder coated cassette system with dedicated top, direct or face fix brackets. On specification the user has the choice between a single coloured extrusion in dedicated colours or a fascia which incorporates the same fabric or contrasting fabric used on the roller blind.

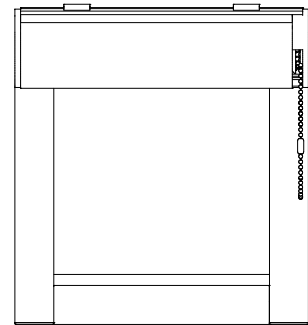
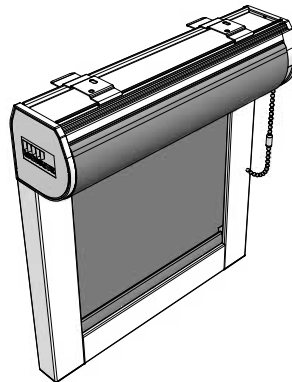

LOUVOLITE SIDE CONTROL SYSTEMS MAXIMUM BLIND SIZE

SYSTEM	FABRIC GROUP	BLIND WIDTH (m) FOR BLIND DROP (m)					MAX HOLDING WEIGHT
		0.5	1.0	1.5	2.0	2.5	
System 32® Red Pin	up to 200g/m sq	4.0	4.0	4.0	4.0		8lb blind at 5mm deflection
	200 > 320g/m sq	3.0	3.0	3.0	3.0		
	320 > 485g/m sq	3.0	3.0	2.5	2.5		
System 40®	up to 200g/m sq	5.0	5.0	5.0	5.0	5.0	9lb blind at 6mm deflection
	200 > 320g/m sq	3.75	3.75	3.75	3.75	3.75	18lb blind at 6mm deflection
System 40+®	320 > 485g/m sq	5.0	5.0	5.0	3.55	2.7	
System 45®	up to 200g/m sq	6.0	6.0	6.0	6.0	6.0	12lb blind at 9mm deflection
	200 > 320g/m sq	4.75	4.75	4.75	4.75	4.75	
	320 > 485g/m sq	6.0	6.0	6.0	5.0	4.0	

Your Louvolite Blockout System Distributor:



UK MANUFACTURED

www.louvolitecommercial.com

CI/SIB 1976 reference by SIB Agency		
(76.7)	X	